

MAGNETIC SENSOR SYSTEMS

Tubular Low Profile Clapper Solenoid

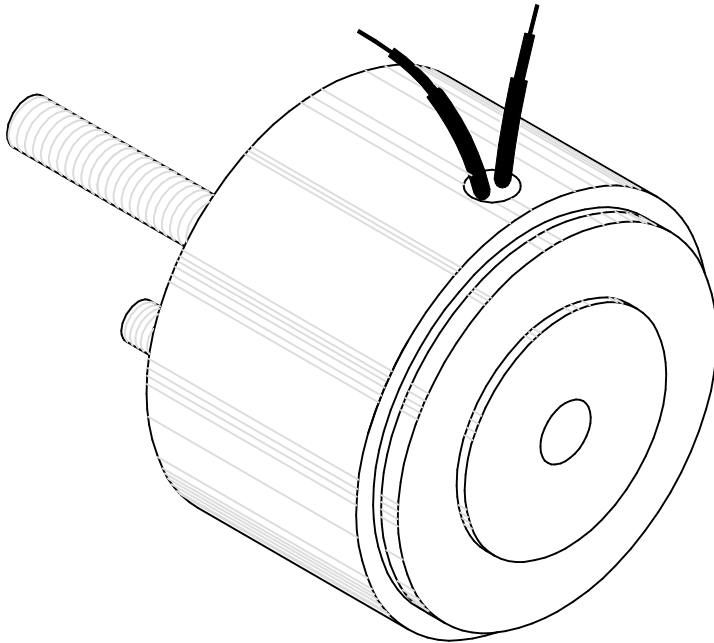

Series S-16-261
2 5/8" DIA X 1.56"
[66.8 mm X 39.6 mm]

TOTAL WEIGHT: 34.7 OUNCES [984 GR]

PLUNGER WEIGHT: 9.3 OUNCES [264 GR]

duty cycle	1	1/2	1/4	1/10
maximum "ON" time, (Sec.)	∞	230	90	30
watts	20	40	80	200
approximate ampere turns	1200	1700	2400	3800

AWG number	resistance (Ω)	volts DC	volts DC	volts DC	volts DC
19	1.4	5.2	7.3	10.3	16.3
20	1.8	5.8	8.2	11.5	18.2
21	3.0	7.7	10.9	15.3	24.3
22	4.5	9.6	13.6	19.2	30.5
23	7.8	12.1	17.2	24.2	38.3
24	12.0	15.5	21.9	31.0	49.0
25	18.5	19.1	27.1	38.3	60.6
26	32.5	25.1	35.5	50.2	79.4
27	48.4	31.4	44.5	62.8	99.4
28	75.2	39.6	56.1	79.2	125
29	127	50.9	72.1	102	161
30	201	63.4	89.9	127	201
31	313	78.3	111	157	248
32	469	97.6	138	195	309
33	770	124	176	249	393
34	1330	161	228	321	509
35	2257	207	293	413	654

HEAT SINK: For proper heat dissipation, body of solenoid should be mounted on an equivalent of 5.0" x 5.0" x 1/4" aluminum plate in an unrestricted flow of air.

MAGNETIC SENSOR SYSTEMS

S-16-261

MECHANICAL DIMENSIONS

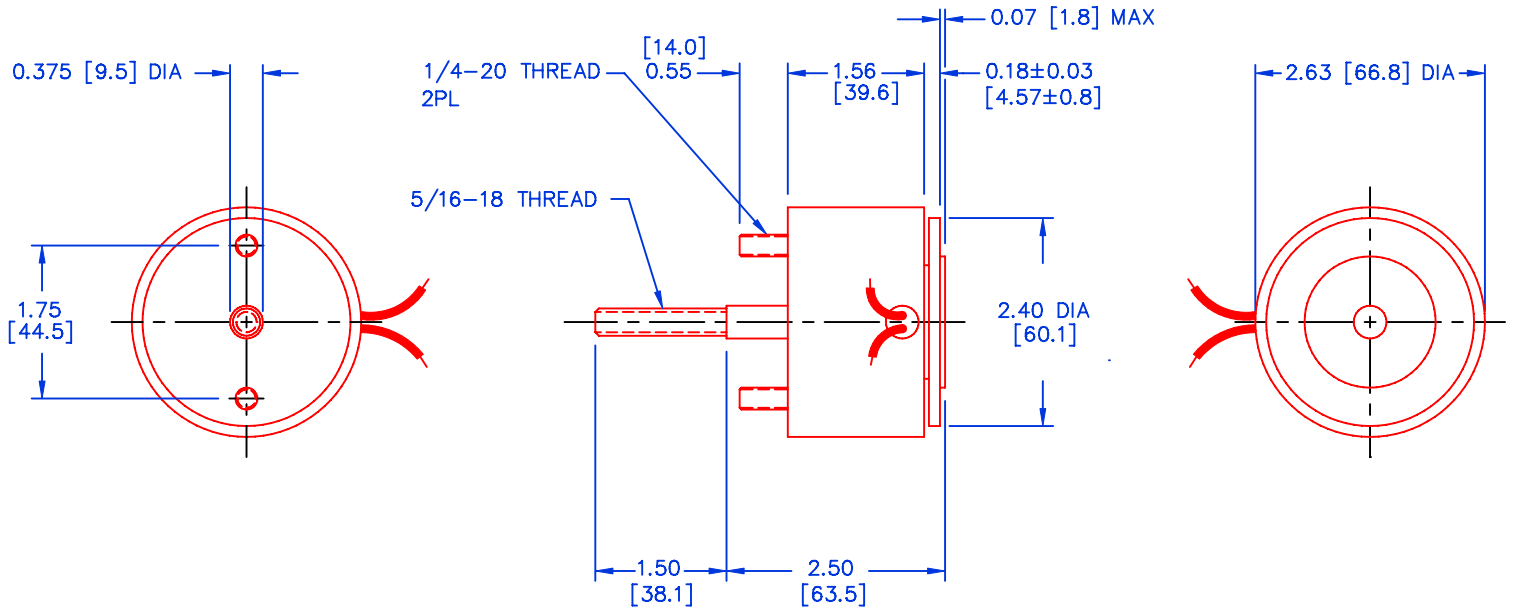

TOLERANCES: (UNLESS NOTED)
 0.XXX: ±0.005
 0.XX : ±0.010
 X/X: ±1/64
 COIL RESISTANCE: ±10%
 DIMENSIONS IN INCHES [mm]

SOLENOID SHOWN ENERGIZED

TYPICAL PUSH FORCE VERSUS STROKE

