

# MAGNETIC SENSOR SYSTEMS

## *Pull Type D-Frame Solenoid*

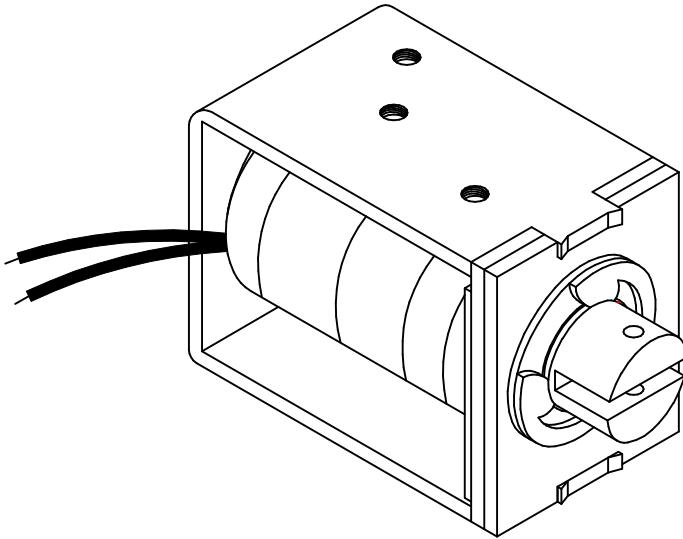

**Series S-20-150**  
1.18" X 1.50" X 2.03"

TOTAL WEIGHT: 11.1 OUNCES

PLUNGER WEIGHT: 2.1 OUNCES

duty cycle	1	1/2	1/4	1/10
maximum "ON" time, (Sec.)	∞	200	100	30
watts	10	20	40	100
approximate ampere turns	1150	1650	2300	3700

AWG number	resistance	volts DC	volts DC	volts DC	volts DC
19	0.53	2.3	3.4	4.7	7.5
20	0.90	3.1	4.4	6.2	9.9
21	1.4	3.8	5.5	7.7	12.3
22	2.3	4.8	6.9	9.6	15.4
23	4.0	6.0	8.6	11.9	19.2
24	6.1	7.6	10.9	15.3	24.5
25	9.1	9.3	13.3	18.5	29.8
26	14.7	12.0	17.2	24.0	38.6
27	23.3	14.2	20.4	28.4	45.8
28	40.4	19.6	28.1	39.1	62.9
29	56.7	23.5	33.7	46.9	75.5
30	93.4	29.9	42.9	59.8	96.3
31	154	38.6	55.4	77.2	124
32	221	46.8	67.2	93.6	151
33	460	67.6	97.0	135	217
34	553	75.9	109	152	244
35	893	96.3	138	193	310
36	1373	121	173	241	388

HEAT SINK: For proper heat dissipation, body of solenoid should be mounted on an equivalent of 4.0" x 4.0" x 1/8" aluminum plate in an unrestricted flow of air.

# MAGNETIC SENSOR SYSTEMS

S-20-150

## MECHANICAL DIMENSIONS

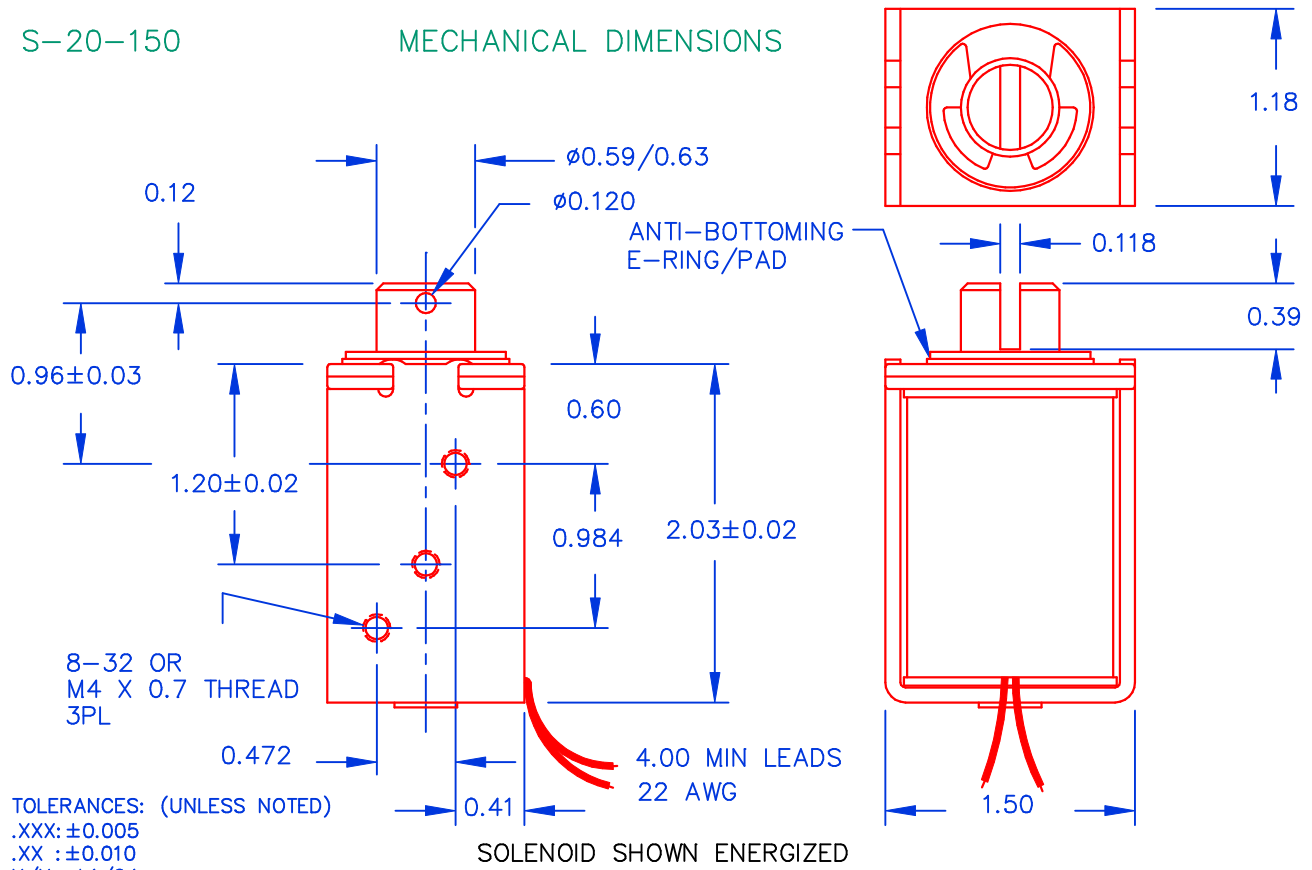

## TYPICAL PULL FORCE VERSUS STROKE

