

MAGNETIC SENSOR SYSTEMS

Pull Type Tubular Solenoid

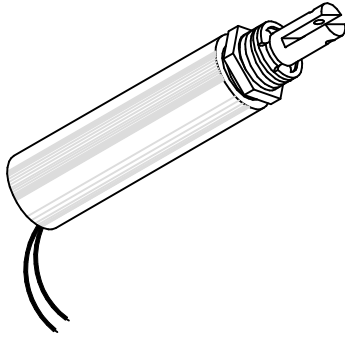

Series S-16-50
1/2" DIA X 1.6"

TOTAL WEIGHT: 1.12 OUNCES

PLUNGER WEIGHT: 0.22 OUNCES

duty cycle	1	1/2	1/4	1/10
maximum "ON" time, (Sec.)	∞	180	50	10
watts	4.5	9	18	45
approximate ampere turns	700	990	1400	2210

AWG number	resistance	volts DC	volts DC	volts DC	volts DC
25	0.93	2.1	3.0	4.2	6.6
26	1.67	2.7	3.9	5.5	8.6
27	2.33	3.3	4.7	6.6	10.5
28	4.36	4.4	6.2	8.8	13.8
29	5.81	5.0	7.1	10.0	15.8
30	11.2	7.1	10.1	14.2	22.5
31	15.2	8.1	11.4	16.2	25.5
32	23.4	9.9	14.0	19.8	31.2
33	39.8	13.4	18.9	26.8	42.3
34	65.2	17.2	24.4	34.5	54.4
35	106	22.3	31.5	44.6	70.4
36	158	26.2	37.1	52.4	82.7
37	261	35.0	49.5	70.0	111
38	381	42.5	60.0	84.9	134
39	710	55.2	78.0	110	174
40	1007	67.5	95.4	135	213
41	1566	82.3	117	165	260
42	2417	104	147	207	327

HEAT SINK: For proper heat dissipation, body of solenoid should be mounted on an equivalent of 2.0" x 2.0" x 1/8" aluminum plate in an unrestricted flow of air.

MAGNETIC SENSOR SYSTEMS

S-16-50

MECHANICAL DIMENSIONS

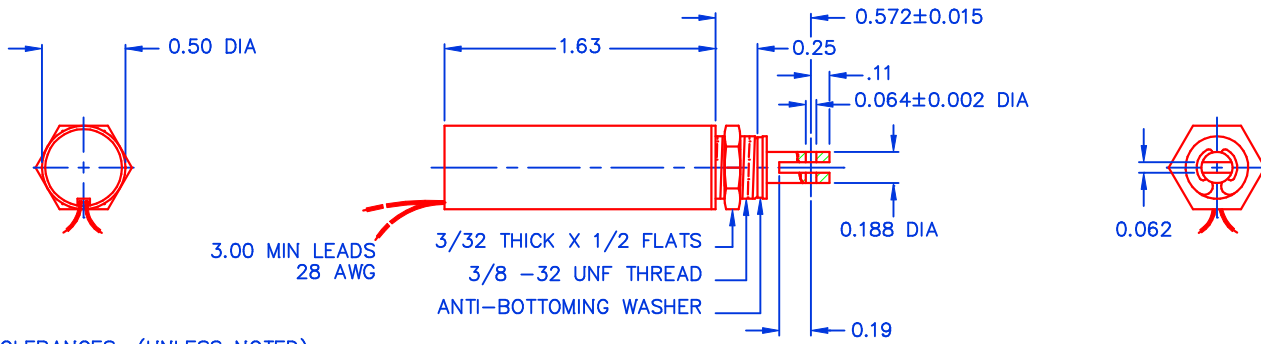

TOLERANCES: (UNLESS NOTED)
 .XXX: ±.005
 .XX : ±.010
 X/X: ±1/64
 COIL RESISTANCE: ±10%

SOLENOID SHOWN ENERGIZED

TYPICAL PULL FORCE VERSUS STROKE

