

# MAGNETIC SENSOR SYSTEMS

## *Pull Type Tubular Solenoid*

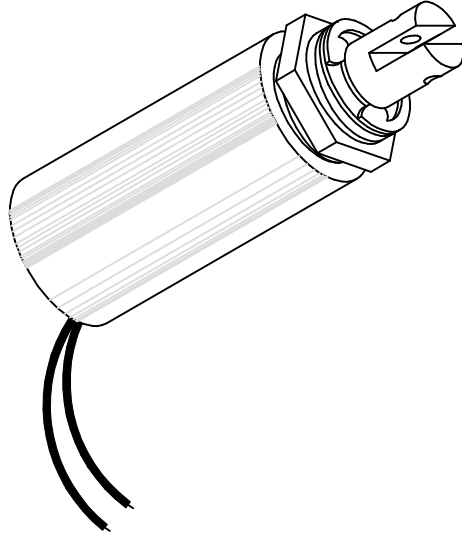

**Series S-20-100**  
**1" DIA X 2"**

TOTAL WEIGHT: 6.2 OUNCES

PLUNGER WEIGHT: 1.6 OUNCES

duty cycle	1	1/2	1/4	1/10
maximum "ON" time, (Sec.)	$\infty$	400	35	10
watts	10	20	40	100
approximate ampere turns	1110	1590	2220	3510

AWG number	resistance	volts DC	volts DC	volts DC	volts DC
23	1.52	3.9	5.5	7.8	12.3
24	2.95	5.4	7.7	10.9	17.2
25	4.01	6.3	9.0	12.7	20.0
26	7.10	8.4	11.9	16.9	26.6
27	9.92	10.0	14.1	19.9	31.5
28	17.1	13.1	18.5	26.2	41.4
29	27.5	16.6	23.5	33.2	52.4
30	46.2	21.5	30.4	43.0	68.0
31	72.0	26.8	37.9	53.7	84.9
32	110	33.2	46.9	66.3	105
33	175	41.8	59.2	83.7	132
34	270	52.0	73.5	104	164
35	450	67.1	94.9	134	212
36	665	81.5	115	163	258
37	1040	102	144	204	323
38	1550	125	176	249	394
39	2750	166	235	332	524
40	4350	209	295	417	660

HEAT SINK: For proper heat dissipation, body of solenoid should be mounted on an equivalent of 4.0" x 4.0" x 1/8" aluminum plate in an unrestricted flow of air.

# MAGNETIC SENSOR SYSTEMS

S-20-100

## MECHANICAL DIMENSIONS

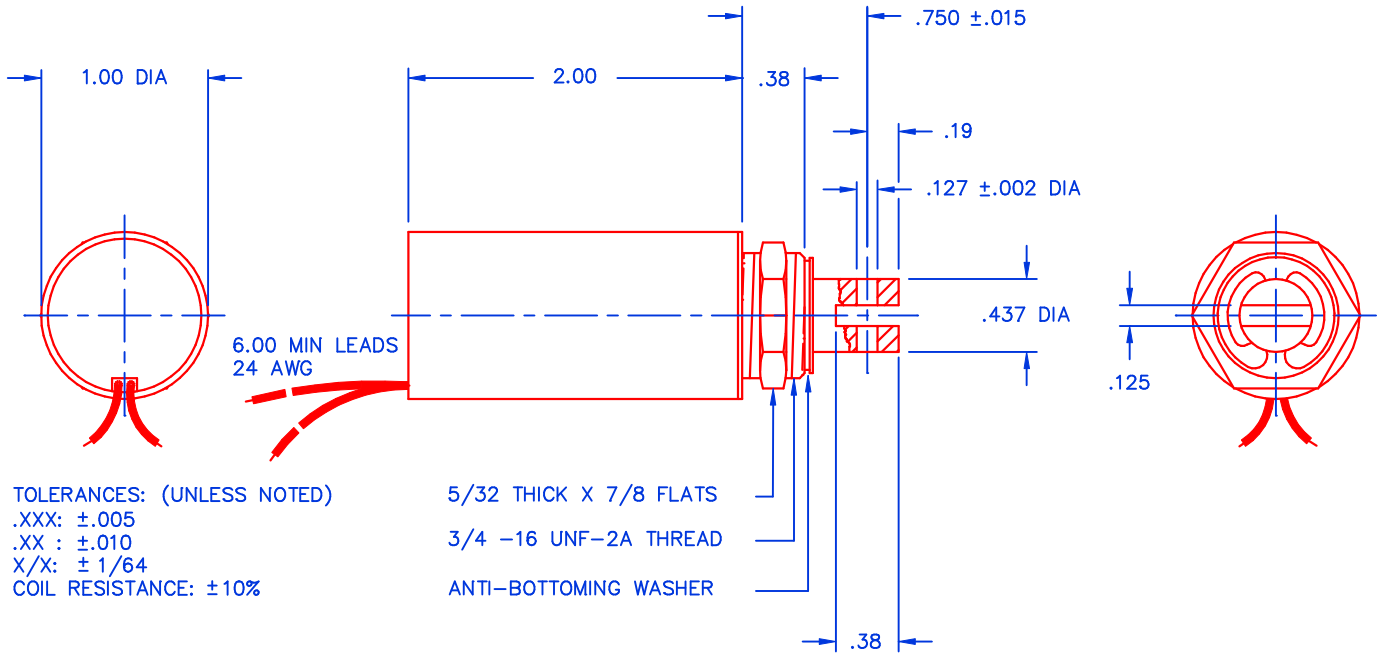

SOLENOID SHOWN ENERGIZED

## TYPICAL PULL FORCE VERSUS STROKE

